

REHABILITATION OF THE MILES HART BRIDGE OVER THE BURNTWOOD RIVER ON PR 391 IN THOMPSON, MB



Project Purpose and Need

The existing bridge, known as the Miles Hart Bridge, is an essential crossing over the Burntwood River to the residents of the City of Thompson and the northern region of the Province of Manitoba. PR 391 serves as a continuation of Provincial Trunk Highway (PTH) 6 through the City, operating as its main thoroughfare, Mystery Lake Road. An average of 2,850 vehicles travel daily across the bridge. This bridge provides the only all weather access road to towns, indigenous communities, mines, and Manitoba Hydro sites North of the 55th Parallel. The existing 5-span, 173 m long, steel I-Girder bridge was built

in 1971 and requires rehabilitation to maintain this important asset in the highway system for another 40 years. The concrete deck will be replaced and the shoulders widened from 0.8m to 2m. The sidewalk will be widened to 2m and moved to the west side of the bridge to provide better access for pedestrians. The steel girders will be repaired and strengthened to meet current standards. A new barrier system will be constructed and include pedestrian safety fencing.

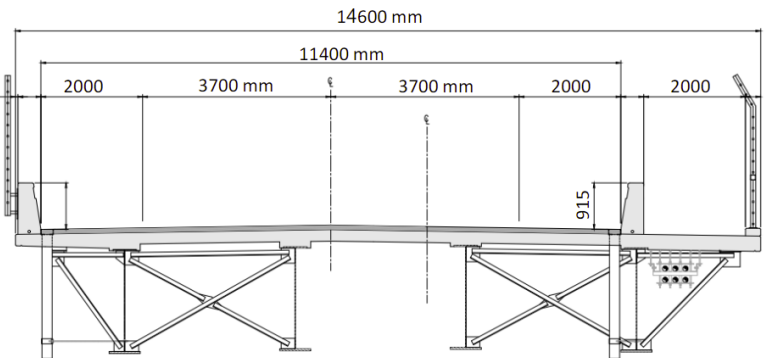

Rehabilitated Bridge Section

Stage 2: Southbound Lane Rehabilitation— March 1st to Nov. 15, 2023

Traffic Control Staging

The bridge will be rehabilitated in stages where one half of the bridge will be closed for construction at a time. Vehicular traffic will be accommodated with one lane of traffic, controlled by temporary traffic signals located at each end of the bridge to allow access to each direction of traffic.

Pedestrian Access

The existing sidewalk will be closed during construction from March 2023 to October 2024. Pedestrian Access will be accommodated at each end of the bridge by a Shuttle Service operating 24 hrs/day, 7 days/week; please call (204) 778-3333 for regular shuttle service or call (204) 667-2777 for shuttle service including Handi-Transit and/or bike transportation. Wait times are expected to be no longer than 30 mins at any time of day.

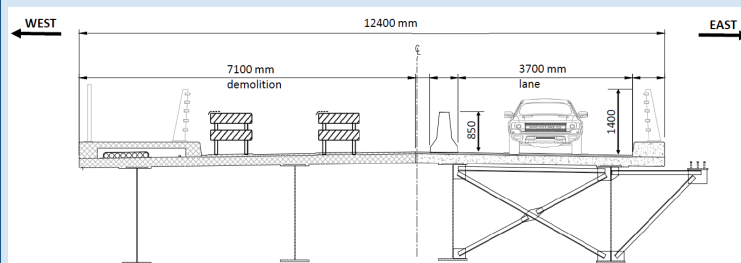

Current Status:

- Repair and Strengthening of steel girders below the roadway began in Summer 2022 and work is currently underway.
- Demolition and reconstruction of Southbound Lane (Stage 2) to commence in early March 2023.
- Project is on schedule and anticipated to be completed in Fall of 2024.

Please Contact Danielle-Magda Salem @ 204-806-3929 if you have any further questions or concerns.